



100415001-2025



Becker County Planning & Zoning
915 Lake Ave
Detroit Lakes, MN 56501
(218) 846-7314
www.co.becker.mn.us

Certificate of Compliance

Inspection Report - Permit #: SS2025-2389

Owner & Property Information

Owner Name:	TIMOTHY RICE	Site Address:	17984 350TH AVE
Mailing Address:	TIMOTHY RICE 17984 350 AVE DETROIT LAKES MN 56501	Township - Sec/Twp/Rng:	ERIE - 24/139/040
Parcel #:	100391001	Legal Description:	PT S1/2 SE1/4 BEG 330' W & 800' S OF NE COR TH W 1197' SLY TO S LN SE1/4 E TO PT 330' W OF SE COR & N TO BEG
Secondary Parcel #:	100415001	Designer:	Scott's Septic Services LLC, L3947 (Scott Ellingson)
		Installer:	Metry Septic & Excavating LLC (Colin Metry)

Inspector Verified Specifications

Insp- Effluent Screen Installed:	No	Insp- Tank Nbr/Size:	1/2250/2
Insp- Alarm Required:	Yes	Insp- Drainfield Type:	Mound
Insp- Lift Pump in System:	Yes	Insp- Drainfield Size:	10X50 ROCK BED
Insp- Number of Bedrooms:	4	Insp- Soil Verification:	#1:SEE ATTACHED #2:N/A #3:N/A

Inspector Verified Setbacks

Insp- Tank Dist to Road	10+	Insp- Drainfield Dist to Road	10+
Insp- Tank Dist to Nearest Prop Line	10	Insp- Drainfield Dist to Nearest Prop Line	10
Insp- Tank Dist to Nearest Structure	10	Insp- Drainfield Dist to Nearest Structure	20
Insp- Tank Dist to Well	50+	Insp- Drainfield Dist to Well	50+
Insp- Tank Dist to OHW	NA	Insp- Drainfield Dist to OHW	NA
Insp- Tank Dist to Pond/Wetland	50	Insp- Drainfield Dist to Pond/Wetland	50
Insp- Tank Dist to Pressure Line		Insp- Drainfield Dist to Pressure Line	

Certificate of Compliance

(Yes) Certificate is hereby granted based upon the application, addendum from, plans, specifications and all other supporting data. With proper maintenance, this system can be expected to function satisfactory, however this is not a guarantee.

Certification Date: 07/01/2025

Zoning Office Signature:

Jeff Rusness - ISTS Inspector

* Certificate of Compliance is not valid unless signed by a Registered Qualified Employee *

Field Review Form

Permit # SS2025-2389

Property and Owner

Owner: TIMOTHY RICE

Parcel Number: 100391001

Site Address: 17984 350TH AVE

Secondary Parcel: 100415001

Home Information

Does the structure contain any of the following elements?

Designer submitted

Inspector verified

Garbage disposal: No

Garbage disposal? Y N

Dishwasher:

Dishwasher? Y N

Grinder pump:

Grinder pump? Y N

Lift pump in bsmt:

Lift pump in basement? Y N

Number of bedrooms: 4

Review - Number of bedrooms: 4

Effluent screen

Effluent screen installed? Y N Mfr: *NA*

Alarm: Yes Type: Electric

Review - Alarm? Y N Type & Mfr: *RA Deroon-*

Lift pump in system: Yes

Review - Lift pump in system? Y N Mfr: *Coeller BW153*

Component Information

Tank size: 2250-2

Review - Tank nbr: 1 size: *2250/2* Mfr: *Therem*

Drainfield type: Mound

Review - Drainfield type: *MOUND FILE 3*

Drainfield size: Full size - 1352
Reduced/warr. size -

Review - Drainfield status: none installed / next spring
Review - Drainfield size: *10x52 Rockbed*

Absorption area size: 9" Under Pipe

Review - Absorption area size:

Chamber type/num: NA
Trench sqft/chamber - NA

Review - Chamber type: *NA*
Review - Trench sqft/chamber: *NA*

Drainfield rock depth: 9" Under Pipe

Review - Rock depth: *10"*

Soil Verification

Vertical separation verified

TYPE 3 system-

Boring #1:

Boring #2:

Boring #3:

Setback Verification

Distance to...	Designer submitted		Inspector verified	
	Tank	Drainfield	Tank	Drainfield
Road	250+	250+	<i>10</i>	<i>10</i>
Nearest prop line	50+	50+	<i>10</i>	<i>10</i>
Nearest structure	65	100+	<i>10</i>	<i>20</i>
Well	80	100+	<i>50+</i>	<i>50+</i>
OHW	NA	NA	<i>NA</i>	<i>NA</i>
Pond/Wetland	50+	50+	<i>50</i>	<i>50</i>
Pressure line			<i>NA</i>	<i>NA</i>

Date System Installed: *6-30-2025*

Installer: *metrix septic*

Inspector: *[Signature]*

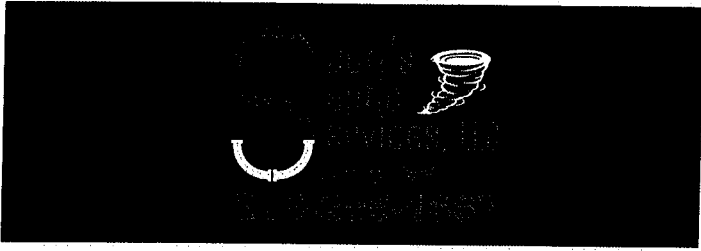

PARCEL# 100391001

YEAR 2025

SCALE —

SKETCH OF PROPERTY

4 beds 600 gpd
 NO G NOP
 2250-2 Septic/Lift
 Type III Mound
 10'x52' Rock Bed
 26'x52' SAA
 1352^{sq}
 3' SAND lift
 2" Supply Line
 1 1/2" Laterals
 3' Holes Apart
 7/32" Holes
 29 gpm
 32.4 ft/h

Inches per dose 4.3"
 Alarm Depth 25.3"
 Pump ON 22.3"
 Pump OFF 18.0"

min dose 66
 max dose 150 (15.5) dose w/D.B.

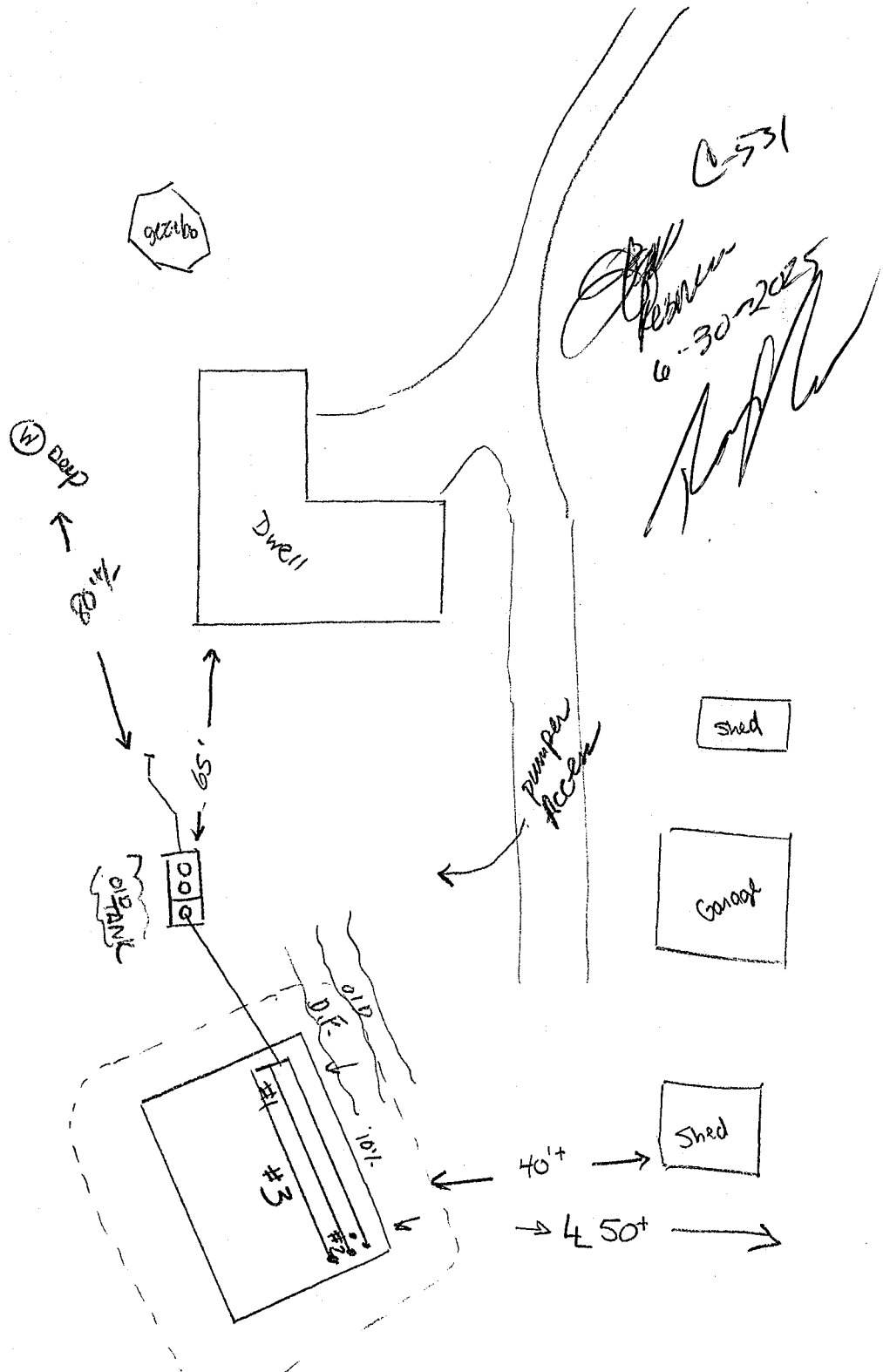



Preliminary Evaluation Worksheet

1. Contact Information

v 04.02.2024

Property Owner/Client: Date Completed:

Site Address: Project ID:

Email: Phone:

Mailing Address: Alt Phone:

Legal Description:

Parcel ID: SEC: TWP: RNG:

2. Flow and General System Information

A. Client-Provided Information

Project Type: New Construction Replacement Expansion Repair

Project Use: Residential Other Establishment:

Residential use: # Bedrooms: Dwelling sq.ft.: Unfinished sq.ft.:

Adults: # Children: # Teenagers:

In-home business (Y/N): If yes, describe:

Water-using devices: *(check all that apply)*

<input type="checkbox"/> Garbage Disposal/Grinder	<input checked="" type="checkbox"/> Dishwasher	<input type="checkbox"/> Hot Tub*
<input type="checkbox"/> Sewage pump in basement	<input checked="" type="checkbox"/> Water Softener*	<input type="checkbox"/> Sump Pump*
<input type="checkbox"/> Large Bathtub >40 gallons	<input type="checkbox"/> Iron Filter*	<input type="checkbox"/> Self-Cleaning Humidifier*
<input checked="" type="checkbox"/> Clothes Washing Machine	<input checked="" type="checkbox"/> High Eff. Furnace*	<input type="checkbox"/> Other: <input type="text"/>

* Clear water source - should not go into system

Additional current or future uses:

Anticipated non-domestic waste:

The above is complete & accurate:

Client signature & date

B. Designer-determined Flow and Anticipated Waste Strength Information

Attach additional information as necessary.

Design Flow: GPD Anticipated Waste Type:

Maximum Concentration BOD: mg/L TSS mg/L Oil & Grease mg/L

3. Preliminary Site Information

A. Water Supply Wells

#	Description	Mn. ID#	Well Depth (ft.)	Casing Depth (ft.)	Confining Layer	STA Setback	Source
1	Deep Well					100+	Owner
2							
3							
4							

Additional Well Information:



Preliminary Evaluation Worksheet

Site within 200' of noncommunity transient well (Y/N)	No	Yes, source:	
Site within a drinking water supply management area (Y/N)	No	Yes, source:	
Site in Well Head Protection inner wellhead management zone (Y/N)	No	Yes, source:	
Buried water supply pipes within 50 ft of proposed system (Y/N)	No		
B. Site located in a shoreland district/area?	No	Yes, name:	N/A
Elevation of ordinary high water level:	N/A	ft. Source:	N/A
Classification:	N/A	Tank Setback:	N/A
		ft. STA Setback:	N/A
		ft.	
C. Site located in a floodplain?	No	Yes, Type(s):	N/A
Floodplain designation/elevation (10 Year):	N/A	ft. Source:	N/A
Floodplain designation/elevation (100 Year):	N/A	ft. Source:	N/A
D. Property Line Id / Source:	<input checked="" type="checkbox"/> Owner	<input type="checkbox"/> Survey	<input checked="" type="checkbox"/> County GIS
	<input type="checkbox"/> Plat Map	<input type="checkbox"/> Other:	
E. ID distance of relevant setbacks on map:	<input type="checkbox"/> Water	<input type="checkbox"/> Easements	<input checked="" type="checkbox"/> Well(s)
	<input checked="" type="checkbox"/> Building(s)	<input checked="" type="checkbox"/> Property Lines	<input type="checkbox"/> OHWL
	<input type="checkbox"/> Other:		

4. Preliminary Soil Profile Information From Web Soil Survey (attach map & description)

Map Units:	267E Snellman Sandy Loam	Slope Range:	15-30	%
List landforms:	Moraines			
Landform position(s):	Back/ Side Slope			
Parent materials:	Till			
Depth to Bedrock/Restrictive Feature:	6	in	Depth to Watertable:	
Depth to Watertable:				
Map Unit Ratings	Septic Tank Absorption Field- At-grade:	Extremely Limited		
	Septic Tank Absorption Field- Mound:	Extremely Limited		
	Septic Tank Absorption Field- Trench:	Extremely Limited		

5. Local Government Unit Information

Name of LGU:	Becker County Planning & Zoning
LGU Contact:	Kyle Vareberg
LGU-specific setbacks:	
LGU-specific design requirements:	
LGU-specific installation requirements:	

Notes: Installing a Type III Mound System



Field Evaluation Worksheet

1. Project Information

v 04.02.2024

Property Owner/Client: Project ID:

Site Address: Date Completed:

2. Utility and Structure Information

Utility Locations Identified Gopher State One Call # Any Private Utilities:

Locate and Verify (see Site Evaluation map) Existing Buildings Improvements Easements Setbacks

3. Site Information

Vegetation type(s): Landscape position:

Percent slope: % Slope shape: Slope direction:

Describe the flooding or run-on potential of site:

Describe the need for Type III or Type IV system:

Note:

Proposed soil treatment area protected? (Y/N): If yes, describe:

4. General Soils Information

Filled, Compacted, Disturbed areas (Y/N):

If yes, describe:

Soil observations were conducted in the proposed system location (Y/N):

A soil observation in the most limiting area of the proposed system (Y/N):

Number of soil observations: Soil observation logs attached (Y/N):

Percolation tests performed & attached (Y/N):

5. Phase I. Reporting Information

	Depth		Elevation		
Limiting Condition*:	0	in		ft	*Most Restrictive Depth Identified from List Below Soil Texture: <input type="text" value="Sandy Clay Loam"/> Percolation Rate: <input type="text"/> min/inch Soil Hyd Loading Rate: <input type="text" value="0.45"/> gpd/sq.ft
Periodically saturated soil:	0	in		ft	
Standing water:		in		ft	
Bedrock:		in		ft	
Benchmark Elevation:				ft	Elevations and Benchmark on map? (Y/N): <input type="text"/>
Benchmark Elevation Location:	<input type="text"/>				
Differences between soil survey and field evaluation:	<input type="text"/>				
Site evaluation issues / comments:	<input type="text"/>				
Anticipated construction issues:	<input type="text"/>				



Soil Observation Log

Project ID: **v 04.02.2024**

Client: **Timothy & Annenette Rice** Location / Address: **17984 350th Ave. Detroit Lakes, MN 56501**

Soil parent material(s): (Check all that apply) Outwash Lacustrine Loess Till Alluvium Bedrock Organic Matter Disturbed/Fill

Landscape Position: **Back/Side Slope** Slope shape: **Linear, Linear** Flooding/Run-On potential: **No**

Vegetation: **Grass** Soil survey map units: **267E Snellman Sandy Loam** Surface Elevation-Relative to benchmark: _____

Date/Time of Day/Weather Conditions: **6/16/2025** **PM** Limiting Layer Elevation: _____

Observation #/Location: **#2** Observation Type: **Auger**

Depth (in)	Texture	Rock Frag. %	Matrix Color(s)	Mottle Color(s)	Redox Kind(s)	Indicator(s)	Structure		Consistence
							Shape	Grade	
0"-8"	Medium Sandy Loam	<10	10YR 3/2				Blocky	Weak	Friable
8"-14"	Sandy Clay Loam	<10	10YR 4/4				Blocky	Moderate	Firm
14"+	Sandy Clay Loam	<10	10YR 4/4	10YR 5/1 10YR 5/8	Depletions Concentrations	SZ	Blocky	Moderate	Firm

Comments: **14"**

I hereby certify that I have completed this work in accordance with all applicable ordinances, rules and laws.

Scott Ellingson (Designer/Inspector) **3947** (License #) **6/18/2025** (Date)

Scott Ellingson (Signature)

Optional Verification: I hereby certify that this soil observation was verified according to Minn. R. 7082.0500 subp. 3 A. The signature below represents an infield verification of the periodically saturated soil or bedrock at the proposed soil treatment and dispersal site.

(LGU/Designer/Inspector) (Signature) (Cert #) (Date)



Soil Observation Log

Project ID: **v 04.02.2024**

Client: **Timothy & Annette Rice** Location / Address: **17984 350th Ave. Detroit Lakes, MN 56501**

Soil parent material(s): (Check all that apply) Outwash Lacustrine Loess Till Alluvium Bedrock Organic Matter Disturbed/Fill

Landscape Position: **Back/Side Slope** Slope %: **10.0** Slope shape: **Linear, Linear** Flooding/Run-On potential: **No**

Vegetation: **Grass** Soil survey map units: **267E Snellman Sandy Loam** Surface Elevation-Relative to benchmark: _____

Date/Time of Day/Weather Conditions: **6/16/2025** **PM** Limiting Layer Elevation: _____

Observation #/Location: **#3** Observation Type: **Auger**

Depth (in)	Texture	Rock Frag. %	Matrix Color(s)	Mottle Color(s)	Redox Kind(s)	Indicator(s)	Structure		
							Shape	Grade	Consistence
0"-8"	Medium Sandy Loam	<10	10YR 3/2				Blocky	Weak	Friable
8"-12"	Sandy Clay Loam	<10	10YR 4/4				Blocky	Moderate	Firm
12"+	Sandy Clay Loam	<10	10YR 4/4	10YR 5/1 10YR 5/8	Depletions Concentrations	52	Blocky	Moderate	Firm

Comments: 12"

I hereby certify that I have completed this work in accordance with all applicable ordinances, rules and laws.

Scott Ellingson (Designer/Inspector) Signature: *Scott Ellingson* (Signature) License #: 3947 (License #) Date: 6/18/2025 (Date)

Optional Verification: I hereby certify that this soil observation was verified according to Minn. R. 7082.0500 subp. 3 A. The signature below represents an infield verification of the periodically saturated soil or bedrock at the proposed soil treatment and dispersal site.

(LGU/Designer/Inspector) (Signature) _____ (Cert #) _____ (Date)



1. PROJECT INFORMATION		v 04.02.2024
Property Owner/Client:	<input type="text" value="Timothy & Annette Rice"/>	Project ID: <input type="text"/>
Site Address:	<input type="text" value="17984 350th Ave. Detroit Lakes, MN 56501"/>	Date: <input type="text" value="06/18/25"/>
Email Address:	<input type="text"/>	Phone: <input type="text"/>
2. DESIGN FLOW & WASTE STRENGTH		
Design Flow:	<input type="text" value="600"/> GPD	Anticipated Waste Type: <input type="text" value="Residential"/>
BOD:	<input type="text" value="170"/> mg/L	TSS: <input type="text" value="60"/> mg/L
		Oil & Grease: <input type="text" value="25"/> mg/L
Treatment Level:	<input type="text" value="C"/> <i>Select Treatment Level C for residential septic tank effluent</i>	
3. HOLDING TANK SIZING <i>Holding Tank Sizing: see 7080.2290</i>		
Code Minimum Holding Tank Capacity:	<input type="text"/>	Gallons with <input type="text"/> Tanks or Compartments
Recommended Holding Tank Capacity:	<input type="text"/>	Gallons with <input type="text"/> Tanks or Compartments
The holding tank(s) will be:	<input type="text"/>	<i>Existing tank reuse requires a tank integrity assessment</i>
Type of High Level Alarm:	<input type="text"/>	
	(Alarm Set @ 75% tank capacity measured from inlet to bottom)	
Comments:	<input type="text"/>	
4. SEPTIC TANK SIZING <i>Sizing: See 7080.1930</i>		
A. Residential dwellings:		
Number of Bedrooms (Residential):	<input type="text" value="4"/>	
Code Minimum Septic Tank Capacity:	<input type="text" value="1500"/> Gallons	with <input type="text" value="1"/> Tanks or Compartments
Recommended Septic Tank Capacity:	<input type="text" value="1500"/> Gallons	with <input type="text" value="1"/> Tanks or Compartments
The septic tank(s) will be:	<input type="text" value="All New"/>	<i>Existing tank reuse requires a tank integrity assessment</i>
Comments:	<input type="text"/>	
Effluent Screen & Alarm (Y/N):	<input type="text" value="No"/>	Model/Type: <input type="text"/>
B. Other Establishments:		
Waste received by:	<input type="text"/>	<input type="text"/> GPD x <input type="text"/> Days Hyd. Retention Time
7080 Minimum Septic Tank Capacity:	<input type="text"/>	Gallons with <input type="text"/> Tanks or Compartments
Designed Septic Tank Capacity:	<input type="text"/>	Gallons with <input type="text"/> Tanks or Compartments
The septic tank(s) will be:	<input type="text"/>	<i>Existing tank reuse requires a tank integrity assessment</i>
Comments:	<input type="text"/>	
Effluent Screen & Alarm (Y/N):	<input type="text"/>	Model/Type: <input type="text"/>
<small>* Other Establishments Require Department of Labor and Industry Approval and Inspection for Building Sewer *</small>		



5. PUMP TANK SIZING Sizing: see 7080.2100

Soil Treatment Dosing Tank				Other Component Dosing Tank:			
Pump Tank Capacity (7080 Minimum):	<input type="text" value="500"/>	Gal		Pump Tank Capacity (7080 Minimum):	<input type="text"/>	Gal	
Pump Tank Capacity (Designed):	<input type="text" value="750"/>	Gal		Pump Tank Capacity (Designed):	<input type="text"/>	Gal	
Pump Req:	<input type="text" value="29.0"/>	GPM	Total Head	<input type="text" value="32.4"/>	ft	Pump Req:	<input type="text"/>
						Total Head	<input type="text"/>
Supply Pipe Dia.	<input type="text" value="2.00"/>	in	Dose Vol:	<input type="text" value="67.0"/>	gal	Supply Pipe Dia.	<input type="text"/>
						Dose Vol:	<input type="text"/>

* Flow measurement device must be incorporated for any system with a pump *

6. SYSTEM AND DISTRIBUTION TYPE

Project ID:

Soil Treatment Type:	<input type="text" value="Mound"/>	Distribution Type:	<input type="text" value="Pressure Distribution-Level"/>	
Elevation Benchmark:	<input type="text"/>	ft	Benchmark Location:	<input type="text"/>
MPCA System Type:	<input type="text" value="Type III"/>	Distribution Media:	<input type="text" value="Rock"/>	
Type III/IV/V Details:	<input type="text" value="Top Soil to Restrictions"/>			

7. SITE EVALUATION SUMMARY:

Describe Limiting Condition:

Layers with >35% Rock Fragments? (yes/no) If yes, describe below: % rock and layer thickness, amount of soil credit and any additional information for addressing the rock fragments in this design.

Note:

	Depth		Depth		Elevation	
Limiting Condition:	<input type="text" value="0.0"/>	inches	<input type="text" value="0.00"/>	ft	<input type="text"/>	ft
Minimum Req'd Separation:	<input type="text" value="36"/>	inches	<input type="text" value="3.00"/>	ft	Elevation	
Distribution Media Bottom*:	<input type="text" value="Mound"/>	inches	<input type="text" value="-3.00"/>	ft	<input type="text" value="#VALUE!"/>	ft
					#VALUE!	
Designed Distribution Bottom Elevation:	<input type="text" value="3.00"/>	ft	Mound Minimum Sand Depth:	<input type="text" value="36"/>	inches	

Elevations are critical for system compliance.

*This is the maximum depth to the bottom of the distribution media for required separation. Negative Depth (ft) requires a mound.

A. Soil Texture:

B. Soil Hyd. Loading Rate: GPD/ft²

C. Percolation Rate: MPI

D. Contour Loading Rate:

Note:

E. Measured Land Slope: %

Note:

Comments:

8. SOIL TREATMENT AREA DESIGN SUMMARY

Trench:

Dispersal Area	<input type="text"/>	sq.ft	Sidewall Depth	<input type="text"/>	in	Trench Width	<input type="text"/>	ft
Total Lineal Feet	<input type="text"/>	ft	No. of Trenches	<input type="text"/>	Code Max. Trench Depth	<input type="text"/>	in	
Contour Loading Rate	<input type="text"/>	ft	Minimum Length	<input type="text"/>	ft	Designed Trench Depth	<input type="text"/>	in

Bed:

Dispersal Area	<input type="text"/>	sq.ft	Sidewall Depth	<input type="text"/>	in	Maximum Bed Depth	<input type="text"/>	in
Bed Width	<input type="text"/>	ft	Bed Length	<input type="text"/>	ft	Designed Bed Depth	<input type="text"/>	in

Project ID:

Mound:

Dispersal Area	520.0	sq.ft	Bed Length	52.0	ft	Bed Width	10.0	ft
Absorption Width	26.0	ft	Clean Sand Lift	3.0	ft	Berm Width (0-1%)		ft
Upslope Berm Width	11.7	ft	Downslope Berm	26.1	ft	Endslope Berm Width	18.2	ft
Total System Length	88.5	ft	System Width	47.8	ft	Contour Loading Rate	12.0	gal/ft

At-Grade:

Dispersal Area		sq.ft	Bed Length		ft	Bed Width		ft
Upslope Berm		ft	Downslope Berm		ft	Finished Height		ft
System Length		ft	Endslope Berm		ft	System Width		ft

Level & Equal Pressure Distribution Soil Treatment Area

No. of Laterals	3	Lateral Diameter	1.50	in	Lateral Spacing	2.0	ft	
Perforation Spacing	3.0	ft	Perforation Diameter	7/32	in	Drainback Volume	8.5	gal
Min Dose Volume	66.0	gal	Max Dose Volume	150.0	gal	Total Dosing Volume	75.5	gal

Non-Level and Unequal Pressure Distribution Soil Treatment Area

	Elevation (ft)	Pipe Size (in)	Pipe Volume (gal/ft)	Pipe Length (ft)	Perf Size (in)	Spacing (ft)	Spacing (in)	Minimum Dose Volume
Lateral 1								
Lateral 2								
Lateral 3								
Lateral 4								
Lateral 5								
Lateral 6								
								Maximum Dose Volume
								Total Dosing Volume

9. Organic Loading and Additional Info for HSW or Type IV/V Design - See Organic Loading tab

Organic Loading to Soil Treatment (Based on Waste Strength Data and Organic Loading Design)

A. Organic Loading Based on: B. Minimum required area sq.ft

Technology Strength Reduction (Tretment Level or HSW)

A. Starting Waste Strength Treatment desinged to meet:

Pretreatment Technology: *Must Meet or Exceed Target Level

Model: Units:

Disinfection Technology: *Required for Levels A & B

Model: Units:

10. Comments/Special Design Considerations:

I hereby certify that I have completed this work in accordance with all applicable ordinances, rules and laws.

(Designer)

Scott Ellingson
 (Signature)

(License #)

(Date)

1. SYSTEM SIZING: Project ID: _____ v 04.02.2024

- A. Design Flow: GPD
- B. Soil Loading Rate: GPD/sqft
- C. Depth to Limiting Condition: ft
- D. Percent Land Slope: %
- E. Media (Sand) Loading Rate: GPD/sqft
- F. Mound Absorption Ratio:

TABLE IXa				
LOADING RATES FOR DETERMINING BOTTOM ABSORPTION AREA AND ABSORPTION RATIOS USING PERCOLATION TESTS				
Percolation Rate (MPI)	Treatment Level C		Treatment Level A, A-2, B	
	Absorption Area Loading Rate (gpd/ft ²)	Mound Absorption Ratio	Absorption Area Loading Rate (gpd/ft ²)	Mound Absorption Ratio
<0.1	-	1	-	1
0.1 to 5	1.2	1	1.6	1
0.1 to 5 (fine sand and loamy fine sand)	0.6	2	1	1.6
6 to 15	0.78	1.5	1	1.6
16 to 30	0.6	2	0.78	2
31 to 45	0.5	2.4	0.78	2
46 to 60	0.45	2.6	0.6	2.6
61 to 120	-	5	0.3	5.3
>120	-	-	-	-

Table I				
MOUND CONTOUR LOADING RATES:				
Measured Perc Rate	← OR →	Texture - derived mound absorption ratio		Contour Loading Rate:
≤ 60mpi		1.0, 1.3, 2.0, 2.4, 2.6	→	≤ 12
61-120 mpi	← OR →	5.0	→	≤ 12
≥ 120 mpi*		>5.0*	→	≤ 6*

*Systems with these values are not Type I systems. Contour Loading Rate (linear loading rate) is a recommended value.

2. DISPERSAL MEDIA SIZING

A. Hydraulic Absorption Required Bottom Area: Design Flow (1A) ÷ Design Media Loading Rate(1E)

GPD ÷ GPD/sqft = sq.ft

Optional Upsizing of Dispersal Media Area

B. Larger Bed Area Size or Organic Sizing of Bed Area sq.ft
[see organic loading sheet(2G)]

C. Designed Dispersal Media Area: sq.ft *Larger of 2A or 2B*

D. Enter Dispersal Bed Width: ft *Can not exceed 10 feet*

E. Calculate Contour Loading Rate: Bed Width(2D) X Design Media Loading Rate(1E)

ft X GPD/sqft = gal/ft *Can not exceed Table 1*

F. Calculate Minimum Dispersal Bed Length: Dispersal Bed Area(2C) ÷ Bed Width(2D)

sqft ÷ ft = ft

If a larger dispersal media Length is desired, enter Length(ft):

3. ABSORPTION AREA SIZING

A. Calculate Absorption Width: Bed Width(2D) X Mound Absorption Ratio(1F)

ft X = ft

B. For slopes >1%, the Absorption Width is measured downhill from the upslope edge of the Bed.

Calculate Downslope Absorption Width: Absorption Width(3A) - Bed Width(2D)

ft - ft = ft

4. DISTRIBUTION MEDIA:

Project ID:

Select Dispersal Media:

Enter Either 4A or 4B

A. Rock Depth Below Distribution Pipe

in

B. Registered Media

Registered Media Depth in

Check registered product information for specific application details and design

Specific Media Comments:

5. MOUND SIZING

Project ID:

A. Clean Sand Lift: Required Separation - Depth to Limiting Condition = Clean Sand Lift (1 ft minimum)

ft - ft = ft Design Sand Lift (optional): ft

B. Upslope Height: Clean Sand Lift(5A) + Depth of Media(4AorB) +Depth to Cover Pipe+ Depth of Cover (1 ft)

ft + ft + ft + ft = ft

Land Slope %	0	1	2	3	4	5	6	7	8	9	10	11	12
Upslope Berm Ratio 3:1	3.00	2.91	2.83	2.75	2.68	2.61	2.54	2.48	2.42	2.36	2.31	2.26	2.21
Upslope Berm Ratio 4:1	4.00	3.85	3.70	3.57	3.45	3.33	3.23	3.12	3.03	2.94	2.86	2.78	2.70

C. Select Upslope Berm Multiplier (based on land slope):

D. Calculate Upslope Berm Width: Multiplier (5C) X Upslope Mound Height (5B)

X ft = ft

E. Calculate Drop in Elevation Under Bed: Bed Width(2D) X Land Slope(1D) ÷ 100 = Drop (ft)

ft X % ÷ 100 = ft

F. Calculate Downslope Mound Height: Upslope Height(5B) + Drop in Elevation(5E)

ft + ft = ft

Land Slope %	0	1	2	3	4	5	6	7	8	9	10	11	12
Downslope Berm Ratio 3:1	3.00	3.09	3.19	3.30	3.41	3.53	3.66	3.80	3.95	4.11	4.29	4.48	4.69
Downslope Berm Ratio 4:1	4.00	4.17	4.35	4.54	4.76	5.00	5.26	5.56	5.88	6.25	6.67	7.14	7.69

G. Select Downslope Berm Multiplier (based on land slope):

H. Calculate Downslope Berm Width: Downslope Multiplier(5G) X Downslope Height (5F)

x ft = ft

I. Calculate Minimum Berm to Cover Absorption Area: Downslope Absorption Width(3B) + 4 feet

ft + ft = ft

J. Design Downslope Berm = greater of 5H and 5I: ft

K. Select Endslope Berm Multiplier: (usually 3.0 or 4.0)

L. Calculate Endslope Berm Width = Endslope Berm Multiplier(5K) X Downslope Mound Height(5F)

X ft = ft

M. Calculate Mound Width: Upslope Berm Width(5D) + Bed Width(2D) + Downslope Berm Width(5J)

ft + ft + ft = ft

N. Calculate Mound Length: Endslope Berm Width (5L) + Bed Length(2F) + Endslope Berm Width(5L)

ft + ft + ft = ft

6. MOUND DIMENSIONS (Feet)

Project ID:

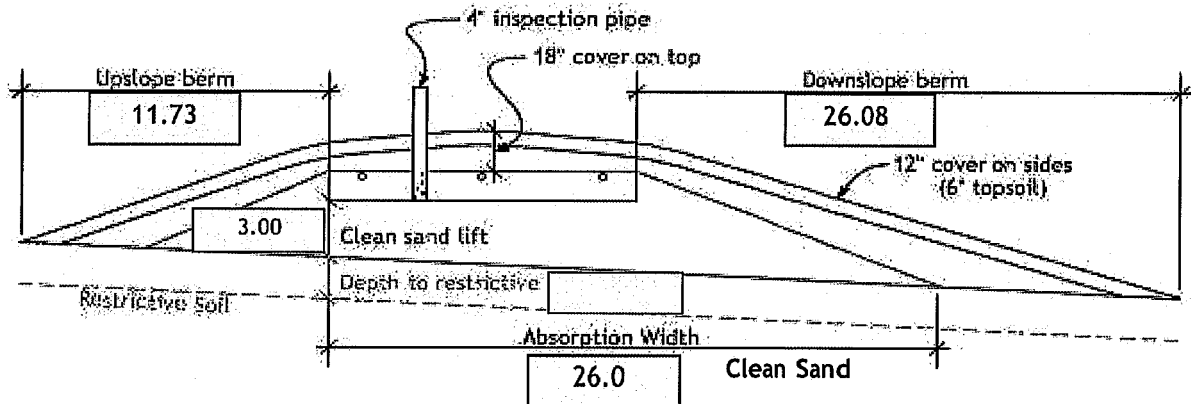
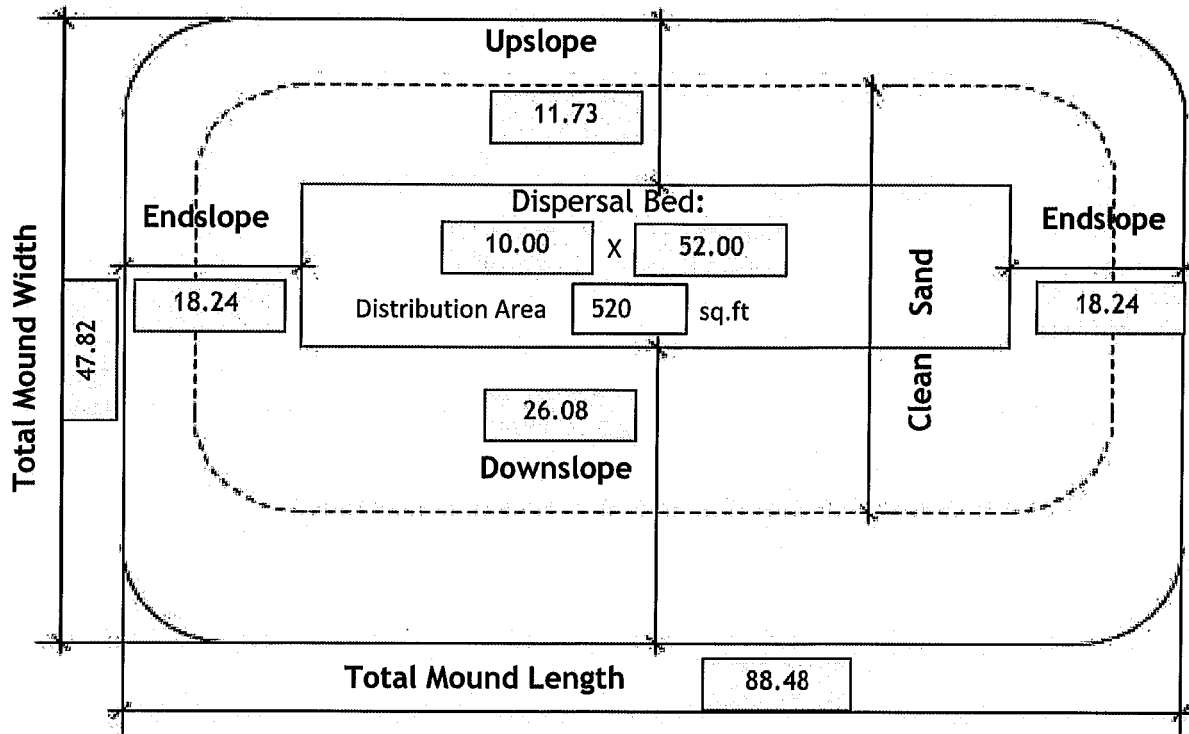

Elevation to Benchmark

Required Separation: (in) Elevation Limiting Layer: ft

Distribution Media: Elevation required Separation: ft

Media Depth (in) Below Pipe Elevation Distribution Media Bottom: ft

Manifold Connection: Lateral Pipe Diameter: (in)

Perforation Size: (in) Perforation Spacing: (in)

If Split and Non-Level Pressure Distribution Used: See Non-Level Pressure Distribution Form

Comments:



Mound to be constructed to dimensions in design. This is an estimate of materials needed.
Individual construction practices may vary quantities.

Project ID:

v 04.02.2024

A. Rock Volume : (Rock Below Pipe + Rock to cover pipe (pipe outside dia + ~2 inch)) X Bed Length X Bed Width = Volume

$$((9 \text{ in} + 3.5 \text{ in}) \div 12) \times 52.0 \text{ ft} \times 10.0 \text{ ft} = 541.7 \text{ cu.ft}$$

Divide cu.ft by 27 cu.ft/cu.yd to calculate cubic yards: $541.7 \text{ cu.ft} \div 27 = 20.1 \text{ cu.yd}$

Add 30% for constructability: $20.1 \text{ cu.yd} \times 1.3 = 26.1 \text{ cu.yd}$

B. Calculate Clean Sand Volume:

Volume Under Rock bed : Average Sand Depth x Media Width x Media Length = cubic feet

$$3.5 \text{ ft} \times 10.0 \text{ ft} \times 52 \text{ ft} = 1820 \text{ cu.ft}$$

For a Mound on a slope from 0-1%

Volume from Length = ((Upslope Mound Height - 1) X Absorption Width Beyond Bed X Media Bed Length)

$$(\text{ } \text{ft} - 1) \times \text{ } \times \text{ } \text{ft} = \text{ }$$

Volume from Width = ((Upslope Mound Height - 1) X Absorption Width Beyond Bed X Media Bed Width)

$$(\text{ } \text{ft} - 1) \times \text{ } \times \text{ } \text{ft} = \text{ }$$

Total Clean Sand Volume : Volume from Length + Volume from Width + Volume Under Media

$$\text{ } \text{cu.ft} + \text{ } \text{cu.ft} + \text{ } \text{cu.ft} = \text{ } \text{cu.ft}$$

For a Mound on a slope greater than 1%

Upslope Volume : ((Upslope Mound Height - 1) x 3 x Bed Length) ÷ 2 = cubic feet

$$(((5.1 \text{ ft} - 1) \times 3.0 \text{ ft} \times 52.0) \div 2) = 318.2 \text{ cu.ft}$$

Downslope Volume : ((Downslope Height - 1) x Downslope Absorption Width x Media Length) ÷ 2 = cubic feet

$$(((6.1 \text{ ft} - 1) \times 16.0 \text{ ft} \times 52.0) \div 2) = 2113.3 \text{ cu.ft}$$

Endslope Volume : (Downslope Mound Height - 1) x 3 x Media Width = cubic feet

$$((6.1 \text{ ft} - 1) \times 3.0 \text{ ft} \times 10.0 \text{ ft}) = 152.4 \text{ cu.ft}$$

Total Clean Sand Volume : Upslope Volume + Downslope Volume + Endslope Volume + Volume Under Media

$$318.2 \text{ cu.ft} + 2113.3 \text{ cu.ft} + 152.4 \text{ cu.ft} + 1820.0 \text{ cu.ft} = 4403.9 \text{ cu.ft}$$

Divide cu.ft by 27 cu.ft/cu.yd to calculate cubic yards: $4403.9 \text{ cu.ft} \div 27 = 163.1 \text{ cu.yd}$

Add 30% for constructability: $163.1 \text{ cu.yd} \times 1.3 = 212.0 \text{ cu.yd}$

C. Calculate Sandy Berm Volume:

Total Berm Volume (approx.) : ((Avg. Mound Height - 0.5 ft topsoil) x Mound Width x Mound Length) ÷ 2

$$((5.6 - 0.5) \text{ ft} \times 47.8 \text{ ft} \times 88.5) \div 2 = 10746.6 \text{ cu.ft}$$

Total Mound Volume - Clean Sand volume - Rock Volume = cubic feet

$$10746.6 \text{ cu.ft} - 4403.9 \text{ cu.ft} - 541.7 \text{ cu.ft} = 5801.0 \text{ cu.ft}$$

Divide cu.ft by 27 cu.ft/cu.yd to calculate cubic yards: $5801.0 \text{ cu.ft} \div 27 = 214.9 \text{ cu.yd}$

Add 30% for constructability: $214.9 \text{ yd}^3 \times 1.3 = 279.3 \text{ cu.yd}$

D. Calculate Topsoil Material Volume: Total Mound Width X Total Mound Length X .5 ft

$$47.8 \text{ ft} \times 88.5 \text{ ft} \times 0.5 \text{ ft} = 2115.5 \text{ cu.ft}$$

Divide cu.ft by 27 cu.ft/cu.yd to calculate cubic yards: $2115.5 \text{ cu.ft} \div 27 = 78.4 \text{ cu.yd}$

Add 30% for constructability: $78.4 \text{ cu.yd} \times 1.3 = 101.9 \text{ cu.yd}$

Project ID:

v 04.02.2024

1. Media Bed Width: ft
2. Media Bed Length: ft
3. Minimum Number of Laterals in system/zone = Rounded up number of $[(\text{Media Bed Width}(1.) - 4) \div 3] + 1$.
- $[(\text{ } - 4) \div 3] + 1 = \text{ } \text{ laterals}$ *Does not apply to at-grades*

4. Designer Selected Number of Laterals: laterals
Cannot be less than line 2 (Except in at-grades)

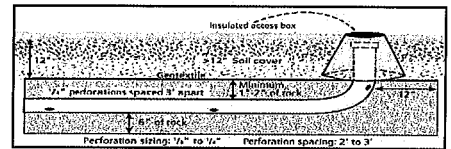

5. Lateral spacing in Bed; *Must be greater than 1 foot and no more than 2 feet from Edge*: ft
6. Length of Laterals = Media Bed Length(2.) - 2 Feet.
- 2ft = ft *Perforation can not be closer then 1 foot from edge.*

7. Select Perforation Spacing: ft
8. Determine the Number of Perforation Spaces. Divide the Length of Laterals(6.) by the Perforation Spacing (7.) and round down to the nearest whole number.

$\text{Number of Perforation Spaces} = \text{ } \text{ ft} \div \text{ } \text{ ft} = \text{ } \text{ Spaces}$

9. Number of Perforations per Lateral is equal to 1.0 plus the Number of Perforation Spaces(8.). Check table below to verify the number of perforations per lateral guarantees less than a 10% discharge variation. The value is double with a center manifold.

$\text{Perforations Per Lateral} = \text{ } \text{ Spaces} + 1 = \text{ } \text{ Perfs. Per Lateral}$

10. Select Perforation Diameter Size: in 0.21875
11. Select Lateral Diameter (See Table): in
12. Select Manifold Connection (End or Center): If Center Manifold Connection the max number of perfs per lateral in the table can be doubled.

Maximum Number of Perforations Per Lateral to Guarantee <10% Discharge Variation											
1/4 Inch Perforations						7/32 Inch Perforations					
Perforation Spacing (Feet)	Pipe Diameter (Inches)					Perforation Spacing (Feet)	Pipe Diameter (Inches)				
	1	1 1/4	1 1/2	2	3		1	1 1/4	1 1/2	2	3
2	10	13	18	30	60	2	11	16	21	34	68
2 1/2	8	12	16	28	54	2 1/2	10	14	20	32	64
3	8	12	16	25	52	3	9	14	19	30	60
3/16 Inch Perforations						1/8 Inch Perforations					
Perforation Spacing (Feet)	Pipe Diameter (Inches)					Perforation Spacing (Feet)	Pipe Diameter (Inches)				
	1	1 1/4	1 1/2	2	3		1	1 1/4	1 1/2	2	3
2	12	18	26	46	87	2	21	33	44	74	149
2 1/2	12	17	24	40	80	2 1/2	20	30	41	69	135
3	12	16	22	37	75	3	20	29	38	64	128

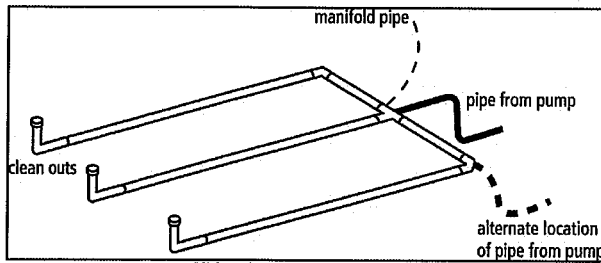

END Connection

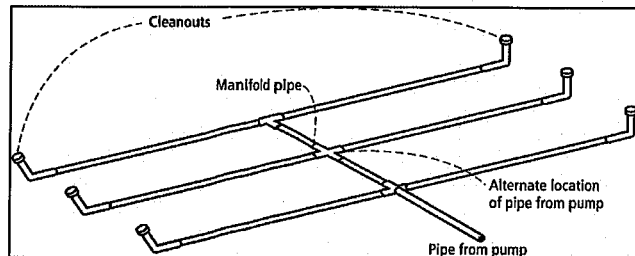

CENTER Connection

Perf Per Lateral: 17

Perf Per Lateral Equal Split: 9 | 8

OPTIONAL Perf Per Lateral Non-Equal Split*: |

* must not exceed maximum number perfs per lateral in table

End Feed Lateral Min Diameter: 1.50

Center Feed Lateral Min Diameter:

13. Total Number of Perforations equals the Number of Perforations per Lateral (9.) multiplied by the Number of Perforated Laterals.(4.)

17 Perf. Per Lat. X 3 Number of Perf. Lat. = 51 Total Number of Perf.

14. Calculate the Square Feet per Perforation.

Recommended value is 4-11 ft² per perforation, Does not apply to At-Grades

a. Bed Area = Bed Width (ft)(1.) X Bed Length (ft)(2.)

10.00 ft X 52.00 ft = 520 sq.ft

b. Square Foot per Perforation = Bed Area (14a) ÷ by Total Number of Perfs (13)

520 sqft ÷ 51 perf = 10 sq.ft/perf

15. Select Minimum Average Head: 1.0 ft

16. Select Perforation Discharge based on Table: 0.56 GPM per Perf

17. Flow Rate = Total Number of Perfs(13.) X Perforation Discharge(16.)

51 Perfs X 0.56 GPM per Perforation = 29.0 GPM

18. Volume of Liquid Per Foot of Distribution Piping (Table II): 0.110 Gallons/ft

19. Volume of Distribution Piping = Number of Perforated Laterals(4.) X Length of Laterals(6.) X Volume of Liquid Per Foot of Distribution Piping (18.)

3 X 50.0 ft X 0.110 gal/ft = 16.5 Gallons

20. Minimum Delivered Volume = Volume of Distribution Piping (19.) X 4

16.5 gal X 4 = 66.0 Gallons

21. Maximum Delivered Volume = Design flow x 25%

600 gpd X 25% = 150.0 Gallons

22. Minimum Delivered vs Maximum Delivered evaluation: Volume ratio correct

Perforation Discharge (GPM)				
Head (ft)	Perforation Diameter			
	1/8	3/16	7/32	1/4
1.0 ^a	0.18	0.41	0.56	0.74
1.5	0.22	0.51	0.69	0.9
2.0 ^b	0.26	0.59	0.80	1.04
2.5	0.29	0.65	0.89	1.17
3.0	0.32	0.72	0.98	1.28
4.0	0.37	0.83	1.13	1.47
5.0 ^c	0.41	0.93	1.26	1.65
1 foot	Dwellings with 3/16 inch to 1/4 inch perforations			
2 feet	Dwellings with 1/8 inch perforations Other establishments and ASTS with 3/16 inch to 1/4 inch perforations			
5 feet	Other establishments and ASTS with 1/8 inch perforations			

Pipe Diameter (inches)	Liquid Per Foot (Gallons)
1	0.045
1.25	0.078
1.5	0.110
2	0.170
3	0.380
4	0.661

Comments/Special Design Considerations:



Basic STA Pump Selection Design Worksheet



1. PUMP CAPACITY Project ID: v 04.02.2024

Pumping to Gravity or Pressure Distribution: Pressure

A. If pumping to gravity enter the gallon per minute of the pump: GPM (10 - 45 gpm)

B. If pumping to a pressurized distribution system: 29.0 GPM

C. Enter pump description: Demand Dosing

2. HEAD REQUIREMENTS

A. Elevation Difference 16.0 ft
between pump and point of discharge:

B. Distribution Head Loss: 5 ft

C. Additional Head Loss*: 10.0 ft (due to special equipment, etc.)

* Common additional head loss: gate valve = 1 ft each, globe valve = 1.5 ft each, splitter valve = see manufacturers details

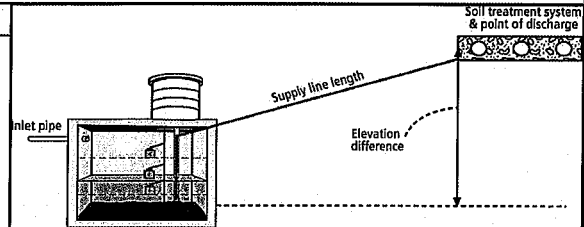

Distribution Head Loss	
Gravity Distribution = 0ft	
Pressure Distribution based on Minimum Average Head Value on Pressure Distribution Worksheet:	
Minimum Average Head	Distribution Head Loss
1ft	5ft
2ft	6ft
5ft	10ft

Table I. Friction Loss in Plastic Pipe per 100ft

Flow Rate (GPM)	Pipe Diameter (inches)			
	1	1.25	1.5	2
10	9.1	3.1	1.3	0.3
12	12.8	4.3	1.8	0.4
14	17.0	5.7	2.4	0.6
16	21.8	7.3	3.0	0.7
18		9.1	3.8	0.9
20		11.1	4.6	1.1
25		16.8	6.9	1.7
30		23.5	9.7	2.4
35			12.9	3.2
40			16.5	4.1
45			20.5	5.0
50				6.1
55				7.3
60				8.6
65				10.0
70				11.4
75				13.0
85				16.4
95				20.1

D. 1. Supply Pipe Diameter: 2.0 in

2. Supply Pipe Length: 50 ft

E. Friction Loss in Plastic Pipe per 100ft from Table I:

Friction Loss = 2.2 ft per 100ft of pipe

F. Determine *Equivalent Pipe Length* from pump discharge to soil dispersal area discharge point. Estimate by adding 25% to supply pipe length for fitting loss. *Supply Pipe Length X 1.25 = Equivalent Pipe Length*

50 ft X 1.25 = 62.5 ft

G. Calculate *Supply Friction Loss* by multiplying *Friction Loss Per 100ft(E.)* by the *Equivalent Pipe Length(F.)* and divide by 100.

Supply Friction Loss = 2.2 ft per 100ft X 62.5 ft ÷ 100 = 1.4 ft

H. *Total Head* requirement is the sum of the *Elevation Difference(2A)* + *Distribution Head Loss(2B)* + *Additional Head Loss(2C)* + *Supply Friction Loss(2G)*

16 ft + 5.0 ft + 10.0 ft + 1.4 ft = 32.4 ft

3. PUMP SELECTION

A pump must be selected to deliver at least **29.0** GPM with at least **32.4** feet of total head.

Comments:



STA Dosing Pump Tank Design Worksheet (Demand Dose)

DETERMINE TANK CAPACITY AND DIMENSIONS Project ID: _____ v 04.02.2024

1. A. Design Flow: GPD C. Tank Use:

B. Code minimum pump tank capacity: Gal D. Designed pump tank capacity: Gal

2. A. Tank Manufacturer: B. Tank Model:

C. Capacity from manufacturer: Gallons

D. Liquid depth of tank from manufacturer: inches

E. Gallons per inch from manufacturer: Gallons per inch

Note: Design calculations are based on this specific tank. Substituting a different tank model will change the pump float or timer settings. Contact designer if changes are necessary.

DETERMINE DOSING VOLUME

3. Calculate *Volume to Cover Pump* (The inlet of the pump must be at least 4-inches from the bottom of the pump tank & 2 inches of water covering the pump is recommended)

(Pump and block height + 2 inches) X *Gallons Per Inch* (2E)

(in + 2 inches) X Gallons Per Inch = Gallons

4. *Minimum Delivered Volume* = 4 X Volume of Distribution Piping:

-Item 19 of the Pressure Distribution STA or Item 11 of Non-level STA Gallons (Minimum dose) inches/dose

5. Calculate *Maximum Pumpout Volume* (25% of Design Flow(1A))

Design Flow: GPD X 0.25 = Gallons (Maximum dose) inches/dose

6. Select a pumpout volume that meets both Minimum and Maximum: Gallons

7. Calculate *Doses Per Day* = Design Flow(1A) ÷ Delivered Volume(6.)

gpd ÷ gal = Doses*

* Doses need to be equal to or greater than 4

Volume of Liquid in Pipe	
Pipe Diameter (inches)	Liquid Per Foot (Gallons)
1	0.045
1.25	0.078
1.5	0.110
2	0.170
3	0.380
4	0.661

8. Calculate Drainback:

A. Diameter of Supply Pipe = inches

B. Length of Supply Pipe = feet

C. Volume of Liquid Per Lineal Foot of Pipe = Gallons/ft

D. Drainback = Length of Supply Pipe(8B) X Volume of Liquid Per Lineal Foot of Pipe(8C)

ft X gal/ft = Gallons

9. Total Dosing Volume = Delivered Volume(6.) + Drainback (8D)

gal + gal = Gallons

10. Minimum Alarm Volume = Depth of alarm (2 or 3 inches) X gallons per inch of tank(2E)

in X gal/in = Gallons

11. Reserve Capacity Volume = [Tank Liquid Depth(2D) - Alarm Float Depth(10.)] x gallons per inch of tank(2E)

[in - in] X gal/in = Gallons

DEMAND DOSE FLOAT SETTINGS Alarm and Pump are to be wired on separate circuits and inspected by the electrical inspector

12. Calculate *Float Separation Distance* using *Dosing Volume*.

Total Dosing Volume(9.) ÷ Gallons Per Inch(2E)

gal ÷ gal/in = inches

13. Measuring from bottom of tank:

A. Distance to set Pump Off Float = Pump + block height + 2 inches

in + 2 in = inches

B. Distance to set Pump On Float = Distance to Set Pump-Off Float(13A) + Float Separation Distance(12.)

in + in = inches

C. Distance to set Alarm Float = Distance to set Pump-On Float(13B) + Alarm Depth (2-3 inches)(10.)

in + in = inches

Inches for Dose: in

Alarm Depth in

Pump On in

Pump Off in

Soil Map—Becker County, Minnesota

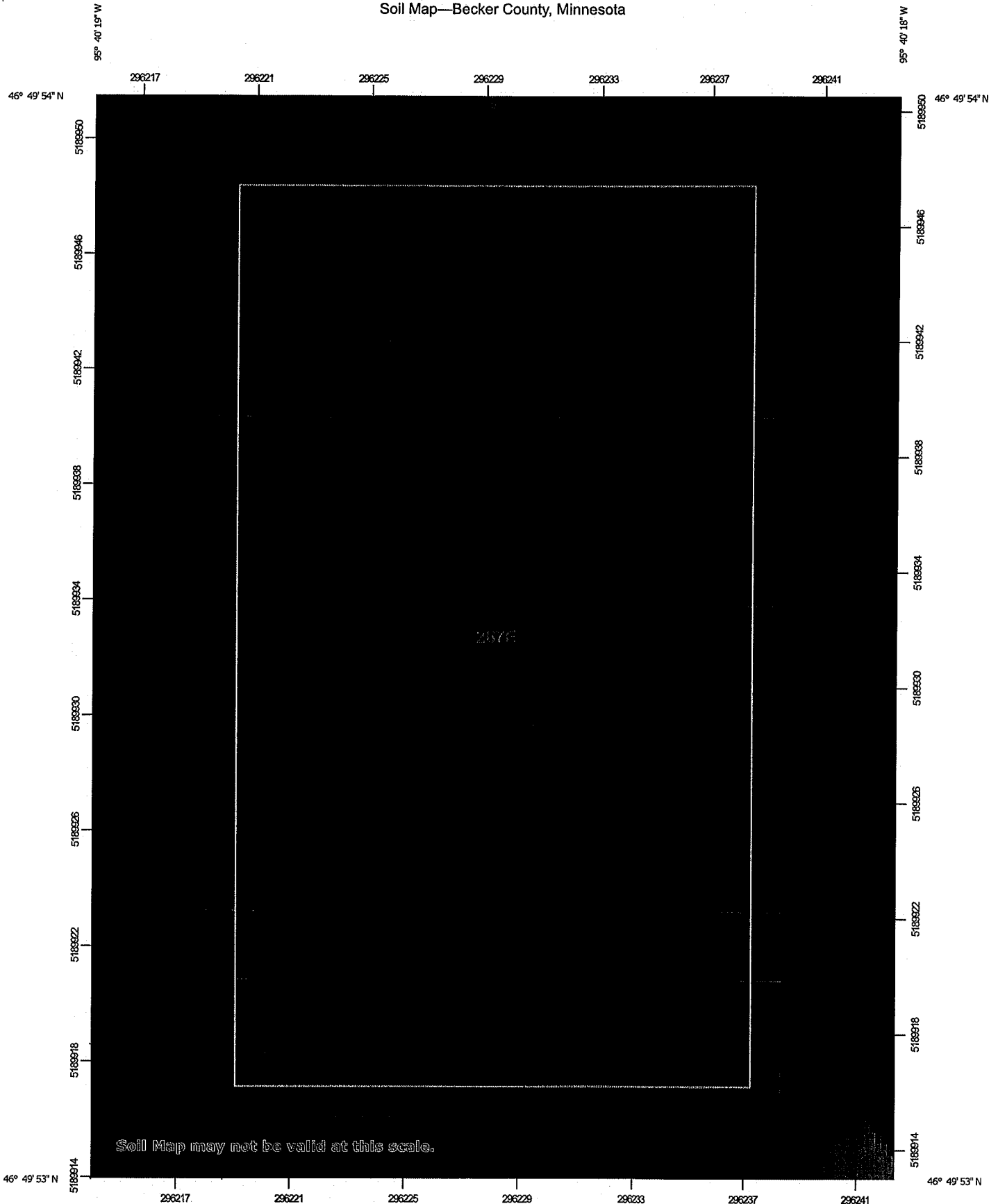

Soil Map may not be valid at this scale.



































Map Scale: 1:183 if printed on A portrait (8.5" x 11") sheet.



Map projection: Web Mercator Corner coordinates: WGS84 Edge tics: UTM Zone 15N WGS84



MAP LEGEND

- Area of Interest (AOI)
 - Area of Interest (AOI) 
- Soils
 - Soil Map Unit Polygons 
 - Soil Map Unit Lines 
 - Soil Map Unit Points 
- Special Point Features
 - Blowout 
 - Borrow Pit 
 - Clay Spot 
 - Closed Depression 
 - Gravel Pit 
 - Gravelly Spot 
 - Landfill 
 - Lava Flow 
 - Marsh or swamp 
 - Mine or Quarry 
 - Miscellaneous Water 
 - Perennial Water 
 - Rock Outcrop 
 - Saline Spot 
 - Sandy Spot 
 - Severely Eroded Spot 
 - Sinkhole 
 - Slide or Slip 
 - Sodic Spot 
- Water Features
 - Streams and Canals 
- Transportation
 - Rails 
 - Interstate Highways 
 - US Routes 
 - Major Roads 
 - Local Roads 
- Background
 - Aerial Photography 
- Other
 - Spoil Area 
 - Stony Spot 
 - Very Stony Spot 
 - Wet Spot 
 - Other 
 - Special Line Features 

MAP INFORMATION

The soil surveys that comprise your AOI were mapped at 1:20,000.

Warning: Soil Map may not be valid at this scale.

Enlargement of maps beyond the scale of mapping can cause misunderstanding of the detail of mapping and accuracy of soil line placement. The maps do not show the small areas of contrasting soils that could have been shown at a more detailed scale.

Please rely on the bar scale on each map sheet for map measurements.

Source of Map: Natural Resources Conservation Service
 Web Soil Survey URL:
 Coordinate System: Web Mercator (EPSG:3857)

Maps from the Web Soil Survey are based on the Web Mercator projection, which preserves direction and shape but distorts distance and area. A projection that preserves area, such as the Albers equal-area conic projection, should be used if more accurate calculations of distance or area are required.

This product is generated from the USDA-NRCS certified data as of the version date(s) listed below.

Soil Survey Area: Becker County, Minnesota
 Survey Area Data: Version 20, Sep 7, 2024

Soil map units are labeled (as space allows) for map scales 1:50,000 or larger.

Date(s) aerial images were photographed: Apr 1, 2021—Oct 1, 2021

The orthophoto or other base map on which the soil lines were compiled and digitized probably differs from the background imagery displayed on these maps. As a result, some minor shifting of map unit boundaries may be evident.

Map Unit Legend

Map Unit Symbol	Map Unit Name	Acres in AOI	Percent of AOI
267E	Snellman sandy loam, 15 to 30 percent slopes	0.1	100.0%
Totals for Area of Interest		0.1	100.0%

Becker County, Minnesota

267E—Snellman sandy loam, 15 to 30 percent slopes

Map Unit Setting

National map unit symbol: 2v0ll
Elevation: 590 to 2,030 feet
Mean annual precipitation: 24 to 30 inches
Mean annual air temperature: 37 to 46 degrees F
Frost-free period: 110 to 160 days
Farmland classification: Not prime farmland

Map Unit Composition

Snellman and similar soils: 88 percent
Minor components: 12 percent
Estimates are based on observations, descriptions, and transects of the mapunit.

Description of Snellman

Setting

Landform: Moraines
Landform position (two-dimensional): Summit, shoulder
Landform position (three-dimensional): Side slope
Down-slope shape: Linear
Across-slope shape: Convex
Parent material: Coarse-loamy till

Typical profile

A - 0 to 2 inches: sandy loam
E - 2 to 16 inches: loamy sand
Bt - 16 to 31 inches: sandy clay loam
C - 31 to 79 inches: sandy loam

Properties and qualities

Slope: 15 to 30 percent
Depth to restrictive feature: More than 80 inches
Drainage class: Well drained
Capacity of the most limiting layer to transmit water (Ksat): Moderately high to high (0.60 to 2.00 in/hr)
Depth to water table: More than 80 inches
Frequency of flooding: None
Frequency of ponding: None
Calcium carbonate, maximum content: 15 percent
Maximum salinity: Nonsaline to very slightly saline (0.0 to 2.0 mmhos/cm)
Available water supply, 0 to 60 inches: Moderate (about 7.5 inches)

Interpretive groups

Land capability classification (irrigated): None specified
Land capability classification (nonirrigated): 6e

Hydrologic Soil Group: B
Ecological site: F057XY018MN - Steep Sandy Upland Forest
Forage suitability group: Steep; Fine Texture (G057XN017MN)
Other vegetative classification: Steep; Fine Texture
(G057XN017MN)
Hydric soil rating: No

Minor Components

Egglake

Percent of map unit: 3 percent
Landform: Moraines
Landform position (two-dimensional): Footslope
Landform position (three-dimensional): Side slope
Down-slope shape: Linear
Across-slope shape: Concave
Ecological site: F057XY015MN - Wet Mixed Forest
Other vegetative classification: Level Swale, Neutral
(G057XN001MN)
Hydric soil rating: Yes

Cathro, frequently ponded

Percent of map unit: 3 percent
Landform: Depressions on moraines
Down-slope shape: Concave
Across-slope shape: Concave
Ecological site: R102AY037SD - Deep Marsh
Other vegetative classification: Not Suited (G057XN024MN)
Hydric soil rating: Yes

Leaflake

Percent of map unit: 2 percent
Landform: Moraines
Landform position (two-dimensional): Summit, shoulder
Landform position (three-dimensional): Side slope
Down-slope shape: Linear
Across-slope shape: Convex
Ecological site: F057XY023MN - Dry Sandy Upland Coniferous
Forest
Other vegetative classification: Sloping Upland, Neutral
(G057XN002MN)
Hydric soil rating: No

Snellman, steep

Percent of map unit: 2 percent
Landform: Moraines
Landform position (two-dimensional): Summit, shoulder
Landform position (three-dimensional): Side slope
Down-slope shape: Linear
Across-slope shape: Convex
Ecological site: F057XY023MN - Dry Sandy Upland Coniferous
Forest
Other vegetative classification: Not Suited (G057XN024MN)

Hydric soil rating: No

Wykeham

Percent of map unit: 2 percent

Landform: Moraines

Landform position (two-dimensional): Backslope

Landform position (three-dimensional): Side slope

Down-slope shape: Convex

Across-slope shape: Convex

Ecological site: F057XY021MN - Loamy Upland Moist Hardwood
Forest

Other vegetative classification: Sloping Upland, Acid
(G057XN006MN)

Hydric soil rating: No

Data Source Information

Soil Survey Area: Becker County, Minnesota

Survey Area Data: Version 20, Sep 7, 2024